

AG Series Electric Heaters



Internal Auxiliary Electric Heat

Installation, Operation &
Maintenance Instructions
97B0016N15
Rev: 25 Jan., 2012

Table of Contents

Overview	3	Ratings	6
Vertical Upflow or Downflow Installation	3	Electrical Data	6
Horizontal Installation	4	Staging Options	6
Wiring	5	Revision Log	8
Setup	5		

This page intentionally left blank

Overview

Overview

The AG Series Auxiliary Electric Heat mounts internally in upflow (Figure 1) or downflow units and mounts directly on the blower outlet of horizontal units (Figure 6). Note the model compatibility Table1. Horizontal units are rated for zero clearance at the unit and 1" clearance for first three feet of duct, vertical units rated for zero clearance for both unit and duct. Downflow units can not be located directly over a discharge register. The discharge plenum must be constructed from non combustible material. The AG electric heat contains a four stage relay control board which activates the elements directly via an internally wired low voltage harness.

Vertical Upflow or Downflow Installation

1. Disconnect power to the unit.
2. Remove blower access panel(s) from the unit and control box cover from the electric heater.
3. Remove blower mounting bolts and drop blower assembly as shown in figure 2. Removal of electrical wiring should not be necessary.
4. Position the electric heater as illustrated in figure 3 with its control box facing the front access panel of the unit. Attach heater to unit using the support pins on the back and bolts on the front.

The electric heater air inlet dimensions should match the unit blower outlet, installer should stop and refer to the unit/heater compatibility chart later in this instruction or consult factory if they do not match.
5. Re-install blower assembly on to electric heater using pins and bolts as before. Check blower electrical wiring for proper connection and remedy any pinched wire(s) or contact with sharp edges.
6. Route the low voltage control harness through one of the 'pie' bushings in the heater control box and plug on to the P2 connector. See figure 4.
7. Install power conduit through the unit corner post as shown in figure 5 and attach directly to the electric heater control box. See figures 7a-c.
8. Replace all covers and panels, heater installation is complete. Proceed to wiring and setup.

Figure 1: Typical vertical unit installation

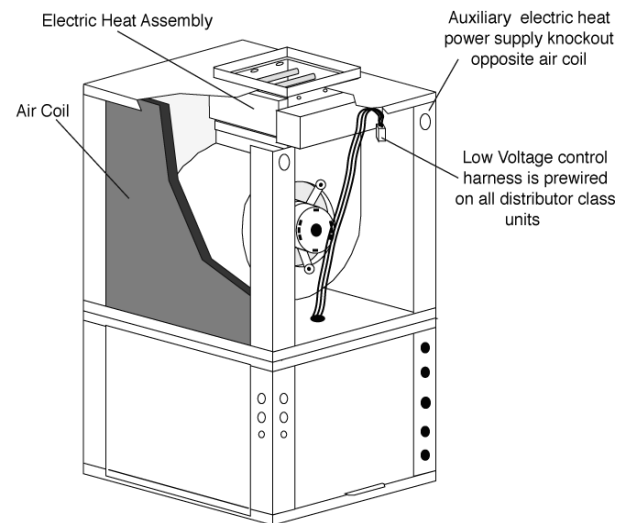

Figure 2: Blower removal

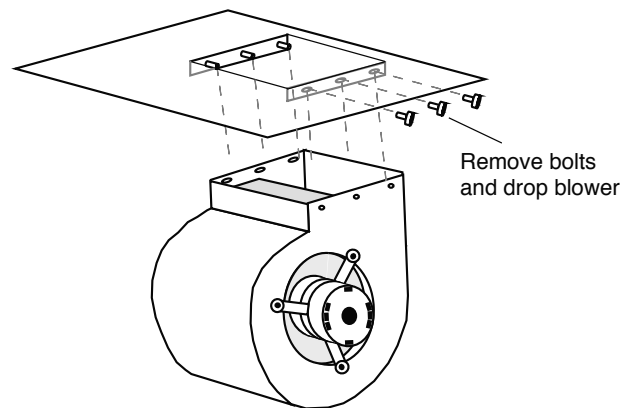
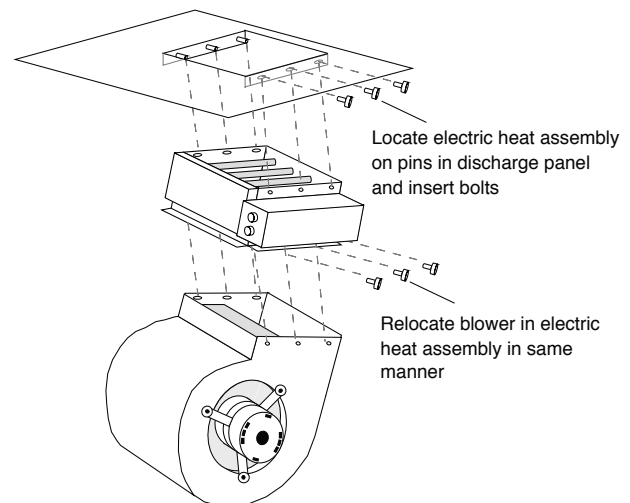

Figure 3: AG electric heat mounting and blower re-installation



Horizontal Installation

Horizontal Installation

1. Disconnect power to the unit.
2. Remove blower access panel from the unit and control box and element covers from the electric heater.
3. Remove and discard blower discharge flanges from the unit but save the screws.
4. Position the electric heater as illustrated herein. Notice that the discharge air opening is off centered in the blower panel. The electric heater must be positioned so that its control box is located vertically over the wide side of this panel.

The electric heater air inlet dimensions should match the unit air outlet, installer should stop and refer to the unit/heater compatibility chart later in this instruction or consult factory if they do not match.

5. Use the saved blower flange screws to attach the heater by its flanges to the unit panel except do not fasten flange on control box side.
6. Use aluminum tape (not provided) to seal all four heater flanges to the blower panel.
7. Locate and route the low voltage control harness through one of the unit corner post or blower panel knockout(s). Seal the penetration 'air tight'. This harness is factory installed and wire-tied to the fan housing.
8. Route the control harness through one of the 'pie' bushings in the heater control box and plug on to the P2 connector. See figure 4.
9. Install power conduit and attach directly to the electric heater control box. See figures 7a-c.
10. Replace all covers and panels, heater installation is complete. Proceed to wiring and setup.

Figure 4: Low Voltage Harness Connection

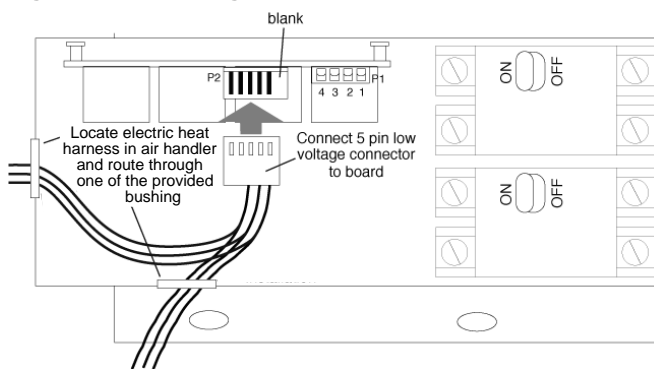

Figure 5: Power Conduit And Wire Routing

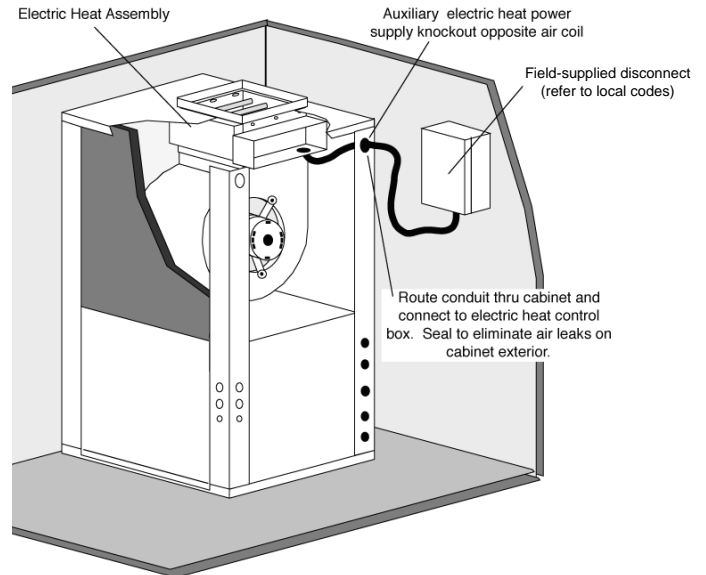

Figure 6. Typical Horizontal Installation

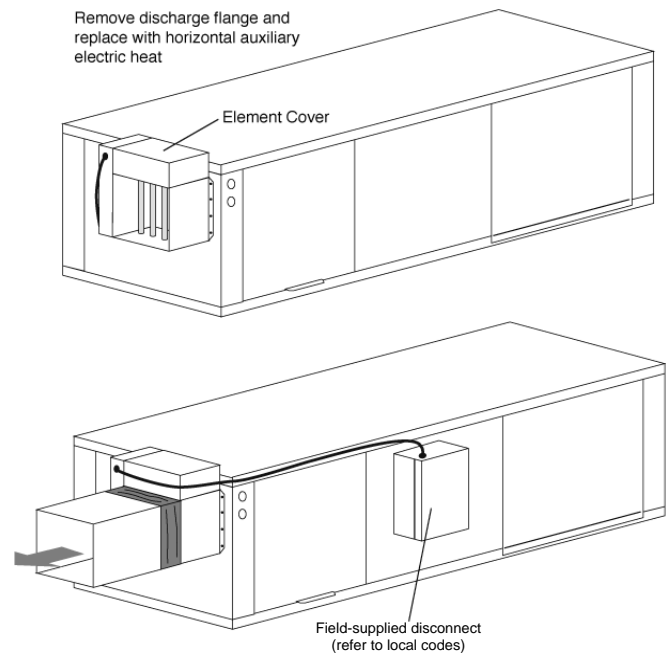

Figure 7a: Power Wiring, Dual Circuits 15, 20kw

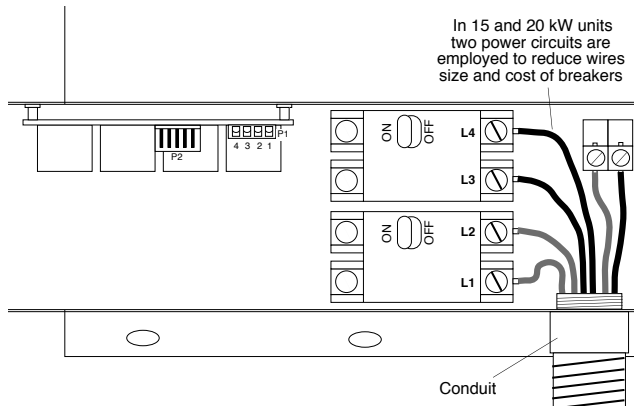
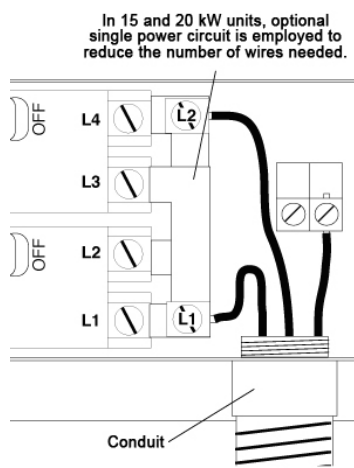

Figure 7b: Power Wiring, Single Circuit 15, 20kw



Wiring and Setup (all models)

1. Install power wiring and connect to power block or circuit breakers. In 15 or 20kW models two power circuits may be used to reduce wiring and breaker costs as in Figure 7a. If a single circuit supply is desired, install the optional single circuit accessory kit (P/N 16B0002N02), as shown in Figure 7b, that can be obtained from your distributor.
2. Ensure unit airflow setting is above minimum airflow rating for the electric heat model from Table 1.
3. Check staging jumpers for the application. Typically only 5 kW (factory setting on all models except 10kW on 20kW models) is needed for first stage electric (W1) to minimize electric demand. This staging can be adjusted by moving the staging jumpers as shown in Figure 8. Whatever is jumped to P1 pin 1 will be energized on 1st stage of electric heat, and P1-2 will be energized as stage 2 electric heat. See Table 3 for staging options.
4. Mark the appropriate box of the electric heat model installed on the additional serial plate on the exterior of the unit.
5. Turn on the power to the unit and the auxiliary electric heat.

Figure 7c: Power Wiring, 4, 5, 8, and 10kw

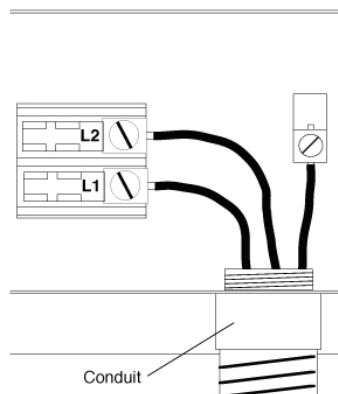
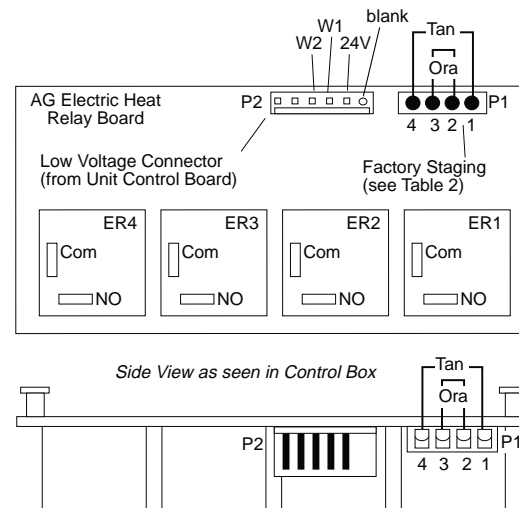

Figure 8: Staging Jumpers

Staging Example on a 15kW unit W1 (first stage) has 5kW ('ER1' 5kW & 'ER4' 0kW) and W2 (second stage) will have 10kW ('ER2 & 3' 5kW each)



Auxiliary Electric Heat Start-up

Put thermostat in emergency heat mode and setpoint to high setting. Verify proper electric heat operation.

Staging Options

Table 1: AG Electric Heat Ratings

Auxiliary Electric Heat Model	RPV Models			kW Rating		Btuh Rating		Minimum CFM Required
	025	036	048, 069	240V	208V	240V	208V	
AGM4A				3.8	2.9	13000	9900	500
AGM5A				4.8	3.6	16300	12300	500
AGM8A				7.6	5.7	25900	19400	650
AGM10A				9.6	7.2	32700	24600	650
AGL4A				3.8	2.9	13000	9900	500
AGL10A				9.6	7.2	32700	24600	1300
AGL15A				14.4	10.8	49100	36900	1350
AGL20A				19.2	14.4	65500	49200	1350

Black area denotes compatibility

Note: Horizontal units rated for zero clearance unit and 1" clearance for the first three feet of duct, Vertical units rated for zero clearance for both unit and duct.

Table 2: AG Electric Heat Electrical Data

Auxiliary Electric Heat Model	Supply Circuit	Heater Amps		Minimum Circuit Amps		Maximum Fuse	
		240V	208V	240V	208V	240V	208V
AGM4A	Single	15.8	14.0	19.8	17.1	20	20
AGM5A	Single	20.0	17.3	25.0	21.6	25	25
AGM8A	Single	31.7	27.5	39.6	34.4	40	35
AGM10A	Single	40.0	34.7	50.0	43.4	50	45
AGM12A	Single	47.5	41.2	59.4	51.5	60	60
	Dual - L1/L2	31.7	27.5	39.6	34.4	40	35
	Dual - L3/L4	15.8	13.7	19.8	17.1	20	20
AGL4A	Single	15.8	14.0	19.8	17.1	20	20
AGL10A	Single	40.0	34.7	50.0	43.4	50	45
AGL15A	Single	60.0	52.0	75.0	65.0	80	70
	Dual - L1/L2	40.0	34.7	50.0	43.4	50	45
	Dual - L3/L4	20.0	17.3	25.0	21.6	25	25
AGL20A	Single	80.0	69.3	100.0	86.6	100	90
	Dual - L1/L2	40.0	34.7	50.0	43.4	50	45
	Dual - L3/L4	40.0	34.7	50.0	43.4	50	45

All heaters rated single phase 208-240V 60Hz
 Wire size based on 60°C (90°C) copper conductor
 All models 15kW or larger feature internal circuit breakers

Wire length based on one way measurement with 2% voltage drop
 All Fuses UL Class K general purpose

Table 3: AG Electric Heat Staging Options

Auxiliary Electric Heat Model	Staging Options	Factory Settings Stage 1	Staging in kW					
			Jumper 1-4, 2-3†		Jumper 1-3, 2-4†		Jumper 1-2-3	
			Stage 1	Stage 2	Stage 1	Stage 2	Stage 1	Stage 2
AGM4A	4	4	4	0	4	0	4	0
AGM5A	5	5	5	0	5	0	5	0
AGM8A	4 or 8	4	4	4	4	4	8	0
AGM10A	5 or 10	5	5	5	5	5	10	0
AGL4A	4, 8 or 12	4	4	8	8	4	12	0
AGL10A	4	4	4	0	4	0	4	0
AGL15A	5 or 10	5	5	5	5	5	10	0
AGL20A	5, 10 or 15	5	5	10	10	5	15	0
AGL20A or C	5, 10, 15 or 20	10	10	10	10	10	15	5

† Factory jumper setting

Accessory Heater Dimensions

Figure 9: Heater Dimensions

NOTE: The maximum recommended air velocity for a supply plenum is 900 fpm. When connecting a plenum to an external supplemental heater, ensure that the air velocity in the plenum does not exceed 900 fpm. Noise and air distribution issues may occur if supply plenum velocities exceed 900 fpm.

AGM4A - 10A

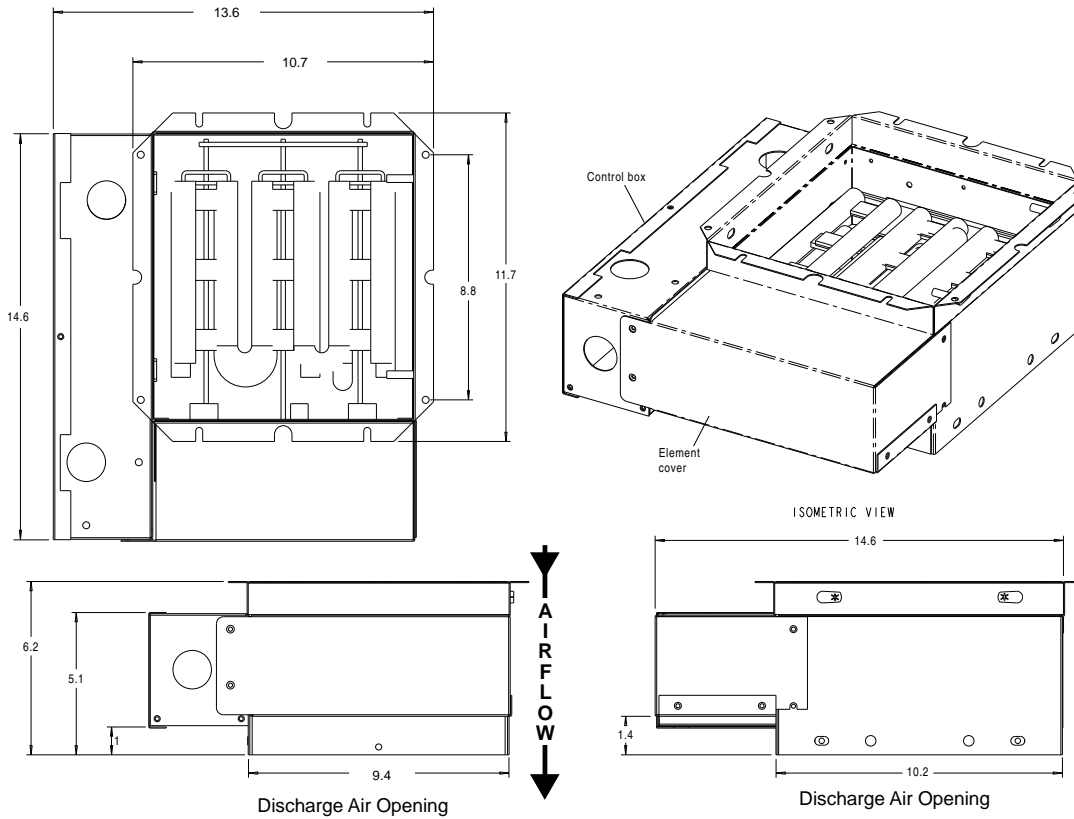

AGL4A - 20A

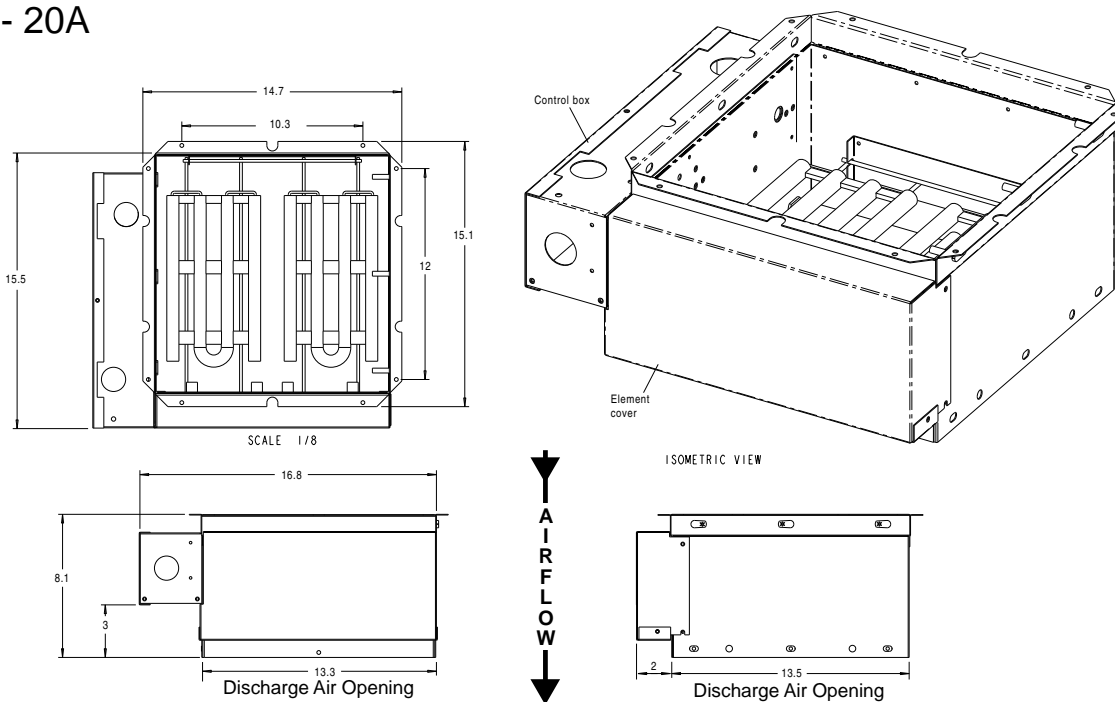

Revision History

Date	Page #	Description
25 Sept. 12	6	Dual Supply Circuit Updated
24 Sept. 10	7	Accessory Heater Dimension Information Added
21 July, 10	All	First Published



97B0016N15

5600 Old Greenwood Road
Ft. Smith, AR 72908
(405) 357-0409

The Manufacturer works continually to improve its products. As a result, the design and specifications of each product at the time for order may be changed without notice and may not be as described herein. Please contact the Manufacturer's Customer Service Department at 1-405-357-0409 for specific information on the current design and specifications. Statements and other information contained herein are not express warranties and do not form the basis of any bargain between the parties, but are merely Manufacturer's opinion or commendation of its products. The management system governing the manufacture of Manufacturer's products is ISO 9001:2000 certified.