

# Geothermal Split System

# HEAT PUMPS

Indoor (RPVS) and Outdoor (RPVE) Models

**Comfort Control<sup>2</sup> System™**

Equipped with

**Comfort Control<sup>2</sup> System™**

- Serial communication enabled
- Increased system reliability and efficiency
- 37+ on-board diagnostic and operating codes
- *Active Protection™* with homeowner "Call for Service" alert
- Exclusive Design with dual 7-segment LED display

**R410A**  
featuring  
earth friendly refrigerant

**RPV E/S**

Two-Stage Cooling/Heating

**Four Models**

- Nominal Sizes 2, 3, 4, & 5 Tons  
[7.03, 10.5, 14.07, & 17.6 kW]



**Rheem**  
**Prestige**  
SERIES

The Rheem *Prestige Series™* High Efficiency Two-Stage RPV E/S Heat Pump can provide year-round heating and cooling comfort. The Rheem RHPL air-handler, equipped with auxiliary heating elements for supplementary heat was designed especially for use with the *Prestige Series™* heat pump. Together they deliver 3 stages of heat and 2 stages of cooling for precise temperature control and optimal energy efficiency.

- The Comfort Control<sup>2</sup> System™ provides over 37+ on-board diagnostics and fault history codes for condensing units with single-phase compressors by detecting system and electrical problems. The integrated diagnostics with Active Protection™ prevents compressor operation when potentially harmful conditions are detected. Sends "Call for Service" alert notification to the thermostat to alert the homeowner of required service.
- Serial Communication Enhanced – When installed with a Serial-Communicating Air Handler (RHPL-HM\*\*\*\*JC) and user interface control (RHC-TST501CMMS) Series 500 thermostat this unit offers 4 or 2 wire installation, auto-configuration, and diagnostic messaging with full communicating capability.
- Legacy Enabled – Unit can be conventionally wired using 24VAC with non-communicating Rheem air-handlers or furnaces with non-communicating thermostat.
- Reliable Two-Stage operation for precise temperature control and On-Demand dehumidification. When matched with ECM gas furnace or air-handler, the system adjusts airflow to help control humidity for unsurpassed comfort in the cooling mode.
- All models meet or exceed a 1000-hour salt spray test per ASTM B117 Standard Practice for Operating Salt Spray Testing Apparatus.
- Dual Fuel capable with select thermostats.

#### Indoor Unit Features

- Factory supplied filter drier for trouble free reliability
- Easy access low profile horizontal control box
- Double isolated compressor for quiet and vibration free operation
- Open service-friendly cabinet (i.e., all components in compressor section can be serviced from the front)

#### Outdoor Unit Features

- Built-in Earth loop circulating pump, flushing valves, and connecting hoses
- Built-in loop expansion tank
- Large, easy access service panels
- Double isolated compressor for quiet and vibration free operation
- Easy access spacious control box



ISO 9001:2008  
Certified



"Proper sizing and installation of equipment is critical to achieve optimal performance. Ask your Contractor for details or visit [www.energystar.gov](http://www.energystar.gov) <<http://www.energystar.gov/>>" for Energy Star Compliance Information.

# FEATURES & BENEFITS OF THE COMFORT CONTROL<sup>2</sup> SYSTEM™

- The Rheem Exclusive Dual 7 Segment LED Display easily shows system status codes and conditions.

- A Sealed Switch replaces the standard contactor and features optical control and latching mechanism. The sealed switch prevents infiltration of insects and dust. A minimal switching arc, by the optical control, offers greater reliability. The latching mechanism consumes less power while reducing chatter.

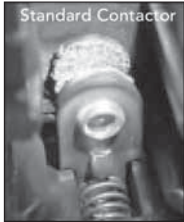

- The Status Indication and System Diagnostics feature thermostat-communication capability, built-in diagnostics, current sensing and high & low switch monitoring. The thermostat communication capability alerts the homeowner of any necessary service requirements. Faster, more accurate service is provided with the built-in diagnostics, by providing the HVAC professional with dependable information. In addition, high and low pressure-switch monitoring prevents the system from operating when damage could occur.

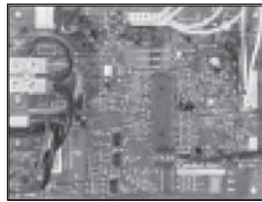

- The Fault Recall feature will allow for the last six fault-codes to be displayed, and will retain these codes even if power failure occurs.
- Built-in short-cycle protection allows the compressor to restart easily without removing the oil from the compressor.
- A 30-second minimum run-time for every compressor call allows the oil to return to the compressor.
- **Active Protection** prevents the compressor from operating if damage could occur.
- The compressor and fan are controlled independently, which reduces the starting load and light dimming.
- A manual push-button is offered to operate the compressor and fan for 5 seconds to allow for an operation check.
- In order to save time and money, replacement automotive fuses can be utilized instead of replacing the entire control board.

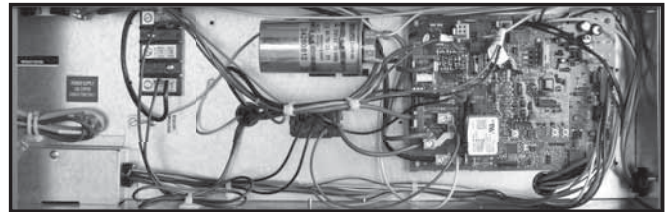

RPVE Model shown

## STANDARD FEATURES

### RPVS/E Heat Pumps

1. 2-stage operation in both cooling and heating mode.
2. Scroll compressor is hermetically sealed and incorporates internal high temperature motor overload protection, and durable insulation on the motor windings. It is externally mounted on grommets to reduce vibration and noise.
3. Compressors have an internal pressure relief assembly to protect against excessive pressure differential.
4. Cabinet is constructed of baked on powder painted galvanized steel.
5. Service valves are standard on all models.
6. Extended range operation (20-120°F EWT) and flow rates as low as 1.5 gpm per ton.
7. Field selectable freeze protection for open well or ground loop applications.
8. Open service-friendly cabinet.
9. Indoor and outdoor models available.
10. Built-in earth loop circulating pump and flushing valves (outdoor model only).
11. Optional hot water generator generates hot water at considerable savings.
12. Oversized coaxial tube water-to-refrigerant heat exchanger operate at low pressure drop.
13. Factory installed liquid line drier.
14. All refrigerant brazing is done in a nitrogen atmosphere.
15. Units are deep evacuated to less than 100 microns prior to refrigerant charging.
16. All joints are both helium and halogen leak tested.
17. Coaxial heat exchanger, refrigerant suction lines, and all water lines are insulated to eliminate condensation problems in low temperature applications.

## Problem-Solving Accuracy

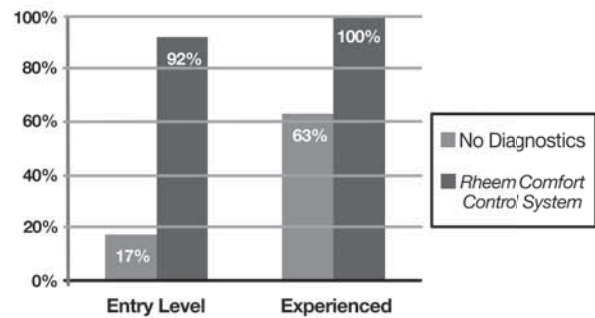

## TWO-STAGE SCROLL<sup>®</sup> COMPRESSOR

The scroll compressor is the key to efficiency for this Rheem model. It's the latest in high-efficiency compressor technology. The advanced scroll compressor offers low noise and vibration characteristics and features tolerance to liquid refrigerant and system contamination. The scroll also has low start torque, eliminating start problems in the field. And its unique design enables the RPVS/E Heat Pump to perform efficiently, quietly and reliably. All models have a 10-year compressor warranty as standard.

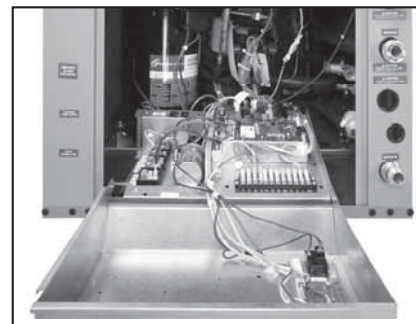

All controls and compressor are accessible for servicing by removal of the service panel. (RPVS Shown)

# MODEL NUMBER IDENTIFICATION

**R**  
Rheem

**P**  
Geothermal  
Heat Pump

**V**  
Efficiency  
Reference  
V = 24 EER

**S**  
Configuration  
S = Indoor Split  
E = Outdoor Split  
(Exterior)

**A**  
Rev Level A =  
Current  
Revision

**036**  
Unit Size  
025  
036  
048  
062  
069

**J**  
Voltage  
J = 208-  
230/60/1

**C**  
Controls  
C = Comfort  
Control<sup>2</sup>  
System

**1**  
Water  
Circuit  
Options  
0 = None  
1 = HWG w/  
internal pump  
(indoor unit only)

**N**  
Heat Exchanger Options  
C = Copper coil  
N = Curpo-Nickel coil

**L**  
Return Air Flow  
Configuration  
N = Not Applicable

**T**  
Supply Air Flow  
Configuration  
N = Not Applicable

**S**  
Standard

## Rheem Heat Pump System

For all season home comfort, performance and energy conservation, choose a Rheem *Prestige Series™* RPV E/S Series Heat Pump with an RHPL-HM Air Handler.

To choose an RHPL-HM Air Handler designed for use with the RPV E/S Heat Pump, refer to the Performance Data Tables and/or the air handler specification sheet.

## SPLIT UNIT ACCESSORIES

### Thermostats



500-Series\*  
Communicating/Programmable

Brand	Unique Model Number Prefix	Descriptor (3 Characters)	Series (3 Characters)	System (2 Characters)	Type (2 Characters)
RHC	-	TST	550	CM	MS
RHC=Rheem		TST=Thermostat	500=Comfort Control <sup>2</sup> System	CM=Communicating	MS=Multi-Stage

\*Photos are representative. Actual models may vary.

## IMPORTANT:

The *Comfort Control<sup>2</sup> System™* requires a communicating RPV V/H/D Heat Pump and the 500-Series Thermostat.

# SPLIT UNIT ACCESSORIES

Item/Description	Part Number	Used With Models			
		025	036	048	060
Split Unit Plastic Mounting Pads					
Outdoor Split Unit Pad w/loop access	AP2436P				
Indoor Split Unit Pad	ASP30				

Remote Mount HWG (Desuperheater) Kit for Outdoor Units					
*Desuperheater coil & pump, mounted in conditioned space.	AHWG1A*RS				

\*Dealer supplied line set required

Soft Start Kit					
Item Description	Part #	Used With Models			
Soft Start Kit for Use With Non-Bleed TXV's	S15B0004N04				

# CLOSED LOOP ACCESSORIES

Item	Part Number	Description	
<b>Flow Controllers</b>			
Composite 3-way valves*	AFCG1C1	1-Grundfos UP26-99 pump	Small Compact, proven design, easy to mount, urethane foam insulated to prevent condensation, includes factory supplied full flow service valves for easy loop charging, Uses double o-ring adaptor fittings for unit and loop connections. Gray polystyrene cabinet with black pumps. Composite 3-way valves. 230VAC pump(s).**
	AFCG2C1	2-Grundfos UP26-99 pumps	
Brass 3-way valves*	AFCG1B1	1-Grundfos UP26-99 pump	Small Compact, proven design, easy to mount, urethane foam insulated to prevent condensation, includes factory supplied full flow service valves for easy loop charging, Uses double o-ring adaptor fittings for unit and loop connections. Gray polystyrene cabinet with black pumps. Brass 3-way valves. 230VAC pump(s).**
	AFCG2B1	2-Grundfos UP26-99 pumps	
	AFCG2B2	2-Grundfos UP26-116 pumps	

Flow Controllers include limited 5-year parts warranty and DOA labor allowance when sold with a unit.

Single pump = 15 GPM @ 20' of head pressure; Dual pumps = 15 GPM @ 40' of head pressure.

The Factory recommends a pressure drop calculation be performed on loop design/installation.

**\*NOTE: Requires adaptor fitting set for loop connection. Hose kit includes adaptor set for hose/unit connections.**

<b>Double O-ring Adaptor Fittings, Set of Two (One Set Required for All Flow Controllers for Loop Connection)</b>		
Fusion	AFC6F	1.25" PE Socket Fusion
	AFC5F	1.00" PE Socket Fusion
Insert	AFC6I	1.25" Brass Barb Insert
	AFC4I	1.00" Brass Barb Insert
Cam	AFC4C	1.00" Cam lever - for flush connections
Thread	AFC4T	1.00" MPT Brass Thread

<b>Flow Controller - Hose Kits &amp; Fittings</b>		
Hose Kit	AHK5EC	Includes double O-Ring x 1.00" barb insert for connection to Flow Controller, 1.00" MPT x 1.00" barb insert el w/PT port for unit connection, & 10' of 1.00" rubber hose.
Additional Hose	ARH510	10' of 1.00" Rubber Hose
	ARH550	50' of 1.00" Rubber Hose

# CLOSED LOOP ACCESSORIES



Flow Controller  
Double O-Ring Connections



AFC5F



AFC6F



AFC4C



Hose Kit  
AHK5EC

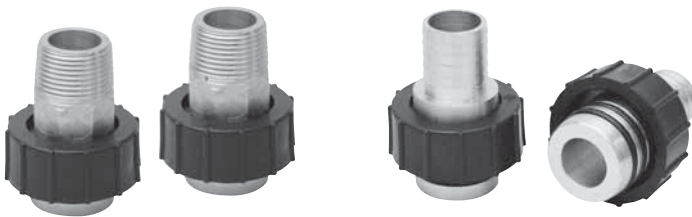

Fusion x MPT  
GFMA65



Elbow w/PT port  
69183134

# OPEN LOOP ACCESSORIES

Item	Part Number	Description
<b>Solenoid &amp; Motorized Valves</b>		
Valves are used with open loop systems in conjunction with a flow regulator.	AVSP5	1.00" FPT, 24 VAC-Solenoid Valve, Plastic
	AVSB5	1.00" FPT, 24 VAC-Solenoid Valve, Brass
	AVMB4	0.75" FPT, 24 VAC-Motorized Valve, Brass w/end switch safety controls
	AVMB5	1" SWT, 24 VAC-Motorized Valve, Brass w/end switch safety controls
	AVMB-PH	Powerhead

<b>Flow Regulators</b>		
Flow Regulators are used with open loop systems in conjunction with a solenoid valve. System requirements are 1.5 to 2.0 GPM/ton for open loop applications. Note: use ball valve downstream to quiet operation.	AFRV*	2 GPM-10 GPM are Brass 0.75" FPT x 0.75 FPT * Specify GPM when ordering. Example 6 gpm = AFR6 - Call Factory for pricing and availability for larger than 9 gpm

<b>Pressure/Temperature Ports</b>		
Used for accessing water pressure and temperature	70022002	Brass 0.25" MPT - Qty. 1
	70022003	Brass 0.50" MPT - Qty. 1

**Open Loop Accessory Notes:**

- Solenoid/Motorized valves are to be located in Leaving water side piping
- Flow Regulators are to be located after Solenoid/Motorized valve
- Pressure/Temperature Ports (P/T fittings) should always be located on unit water coax inlet/outlet to provide unit performance data access
- P/T fittings - choose either .25" or .50" diameter, .25" dia. works with 90 deg. brass swivel fitting, 69183134
- Two stage units should include Open Loop Accessories for each water coax



Plastic Solenoid Valve - AVSP5



Brass Solenoid Valve - AVSB5



P/T Plug  
70022002  
& 70022003



Brass Motorized Valve - AVMB5



Flow Regulator AFRV\*

# LOOP FUSION TOOLS

Part Number	Description
<b>Heating Tool</b>	
HVTD48	Fusion Tool, Double Socket Face

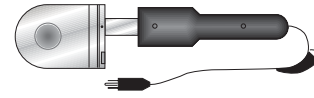

Part Number	Description
<b>Socket Face</b>	
HSF4P	0.75" IPS
HSF5P	1.00" IPS
HSF6P	1.25" IPS
HSF8P	2.00" IPS

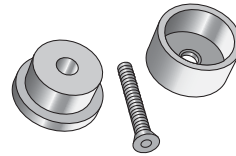

Part Number	Description
<b>Cold Ring</b>	
HCR4P	0.75" IPS
HCR5P	1.00" IPS
HCR6P	1.25" IPS
HCR8P	2.00" IPS

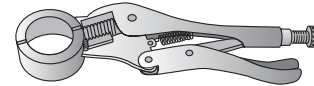

Part Number	Description
<b>Depth Gauge</b>	
HDG4P	0.75" IPS
HDG5P	1.00" IPS
HDG6P	1.25" IPS
HDG8P	2.00" IPS

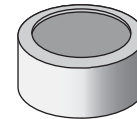

Part Number	Description
<b>Fusion Tool Accessories</b>	
HMB	Fusion Tool Mounting Bracket
HFT	Fusion Timer
HHB	Fusion Tool Cover
HS500	Tempstik 500°F
HS525	Tempstik 525°F
HCT6P	1.25" Chamfer Tool
HCT8P	2.0" Chamfer Tool
HAK7	Kwik Cutter up to 1.25" IPS

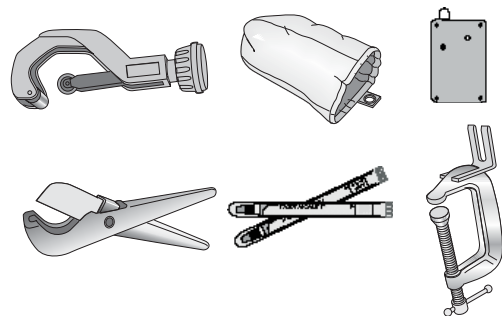

Part Number	Description
<b>Complete Fusion Kits</b>	
HHAK46WDP	0.75" & 1.25" IPS - Double
HHAK468WDP	0.75", 1.25" & 2.00" IPS - Double

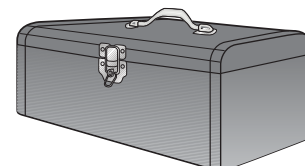

# ADDITIONAL TOOLS

## Service Tools

Item	Part Number	Description
Temperature Measurement	ADT160	Digital Thermometer for use with P/T Ports
Pressure Measurement	APG100	Pressure Gauge, 0-100 psi
Gauge Probe Adapter	APTGA	P/T Port Adapter for use with APG100
Alcohol Anti-Freeze Tester (.9-1)	AHYDA	Specific Gravity Hydrometer
Glycol Anti-Freeze Tester (1-1.07)	AHYDG	Specific Gravity Hydrometer
Control Checker	ATS007	Monitor/checks safety controls



Digital Thermometer

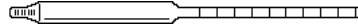

Anti-Freeze Tester



Pressure Gauge and Adapter

## Cooling Performance Data AHRI Standard Conditions

Model	Air Handler	Stage	Water Flow GPM	Airflow CFM	AHRI Cooling Performance 80.6°F DB / 66.2°F WB EAT									
					Ground Water Heat Pump Conditions					Ground Loop Heat Pump Conditions				
					Entering Water Temp	Net Sensible Capacity Btuh	Net Latent Capacity Btuh	Total Capacity Btuh	EER Btuh/W	Entering Water Temp	Net Sensible Capacity Btuh	Net Latent Capacity Btuh	Total Capacity Btuh	EER Btuh/W
RPVE/S025	RHPL-HM2417	1	7.0	600	59°F	15,700	5,500	21,200	29.2	68°F	15,450	5,050	20,500	24.8
		2	8.0	800	59°F	19,850	7,350	27,200	22.6	77°F	19,850	6,550	26,400	18.0
RPVE/S036	RHPL-HM3621	1	8.0	800	59°F	18,900	6,600	25,500	25.3	68°F	19,400	5,600	25,000	21.4
		2	9.0	1100	59°F	29,650	11,750	41,400	21.9	77°F	28,150	10,050	38,200	16.4
RPVE/S048	RHPL-HM4824	1	11.0	1050	59°F	26,250	11,250	37,500	25.8	68°F	26,350	10,250	36,600	22.2
		2	12.0	1650	59°F	35,750	15,750	51,500	20.1	77°F	35,350	13,850	49,200	16.0
RPVE/S062	RHPL-HM6024	1	14.0	1400	59°F	36,250	14,250	50,500	24.7	68°F	35,550	13,050	48,600	21.2
		2	15.0	1850	59°F	44,450	20,350	64,800	20.0	77°F	43,550	18,450	62,000	15.6

All ratings based upon operation at lower voltage of dual voltage rated models  
Cooling capacities based upon 80.6°F DB, 66.2°F WB entering air temperature  
Heating capacities based upon 68°F DB, 59°F WB entering air temperature

## Heating Performance Data AHRI Standard Conditions

Model	Air Handler	Stage	Water Flow GPM	Airflow CFM	AHRI Heating Performance 68°F DB / 59°F WB EAT					
					Ground Water Heat Pump Conditions			Ground Loop Heat Pump Conditions		
					Entering Water Temp	Total Capacity Btuh	COP W/W	Entering Water Temp	Total Capacity Btuh	COP W/W
RPVE/S025	RHPL-HM2417	1	7.0	600	50°F	18,200	4.5	41°F	16,300	4.4
		2	8.0	800	50°F	24,100	4.4	32°F	19,500	3.9
RPVE/S036	RHPL-HM3621	1	8.0	800	50°F	24,400	4.5	41°F	20,200	3.8
		2	9.0	1100	50°F	42,600	4.3	32°F	29,900	3.6
RPVE/S048	RHPL-HM4824	1	11.0	1050	50°F	32,800	4.4	41°F	29,100	4.0
		2	12.0	1650	50°F	46,100	4.4	32°F	36,300	3.7
RPVE/S062	RHPL-HM6024	1	14.0	1400	50°F	41,200	4.2	41°F	36,500	3.8
		2	15.0	1850	50°F	55,300	3.7	32°F	43,100	3.4

All ratings based upon operation at lower voltage of dual voltage rated models  
Cooling capacities based upon 80.6°F DB, 66.2°F WB entering air temperature  
Heating capacities based upon 68°F DB, 59°F WB entering air temperature

# ELECTRICAL & PHYSICAL DATA TABLES

## Electrical Data (RPVS)

Model Number RPV	Phase Frequency (Hz) Voltage (Volts)	Compressor		HWG Pump FLA	Ext Loop FLA	Total Unit FLA	Min Circ Amp	Max Fuse/ HACR
		RLA	LRA					
025	1-60-208/230	10.3	52.0	0.4	4.0	14.7	17.3	25
036	1-60-208/230	16.7	82.0	0.4	4.0	21.1	25.3	40
048	1-60-208/230	21.2	96.0	0.4	4.0	25.6	30.9	50
062	1-60-208/230	25.6	118.0	0.4	4.0	30.0	36.4	60

Min/Max voltage of 197/254

HACR circuit breaker in USA only

All fuses Class RK-5

Current carrying capacity (amperes) of the wire must not be less than the fuse/breaker size used

## Electrical Data (RPVE)

Model Number RPV	Phase Frequency (Hz) Voltage (Volts)	Compressor		Internal Loop Pump FLA	Total Unit FLA	Min Circ Amp	Max Fuse/ HACR
		RLA	LRA				
025	1-60-208/230	10.3	52.0	0.8	11.1	13.7	30
036	1-60-208/230	16.7	82.0	0.8	17.5	21.7	45
048	1-60-208/230	21.2	96.0	1.6	22.8	28.1	50
062	1-60-208/230	25.6	118.0	1.6	27.2	33.6	50

Min/Max voltage of 197/254

HACR circuit breaker in USA only

All fuses Class RK-5

Current carrying capacity (amperes) of the wire must not be less than the fuse/breaker size used

HWG Module	Voltage	Pump FLA	Total FLA	Min Circuit Amps	Min Wire Size
AHWG1AARS	115/60/1	0.52	0.52	1.20	14 ga.
AHWG1AGRS	208/230/60/1	0.40	0.40	0.90	14 ga.

## Physical Data

Model	RPVS				RPVE			
	025	036	048	062	025	036	048	062
Compressor (1 Each)	Copeland UltraTech Two-Stage Scroll				Copeland UltraTech Two-Stage Scroll			
Factory Charge HFC410a (oz) [kg]	92 [2.61]	120 [3.40]	142 [4.02]	204 [5.78]	92 [2.61]	120 [3.40]	142 [4.02]	204 [5.78]
<b>Water Connection Size</b>								
(inches)	1" Swivel				3/4 (MPT)		1 (MPT)	
<b>HWG Connector Size</b>								
HWG Lines Sweat Connections (in.)	1" Swivel				5/8 (O.D. Sweat)			
<b>Horizontal</b>								
Vapor Line Sweat Connection (in.)	7/8	7/8	7/8	7/8	7/8	7/8	7/8	7/8
Liquid Line Sweat Connection (in.)	3/8	3/8	1/2	1/2	3/8	3/8	1/2	1/2
Weight - Operating, lb [kg]	203 [92]	221 [100]	250 [113]	265 [120]	223 [101]	241 [109]	250 [113]	265 [120]
Weight - Packaged, lb [kg]	218 [99]	236 [107]	265 [120]	280 [127]	238 [108]	256 [116]	285 [129]	300 [136]
Maximum Working Water Press (psi [kPa])					100 [689]	100 [689]	100 [689]	100 [689]

# RPVS INDOOR COMPRESSOR SECTION

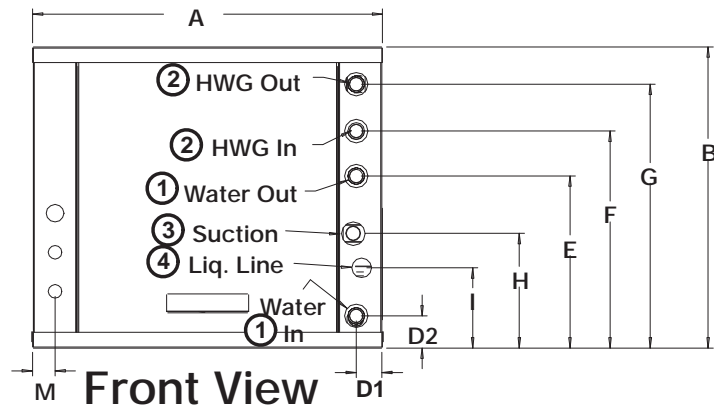
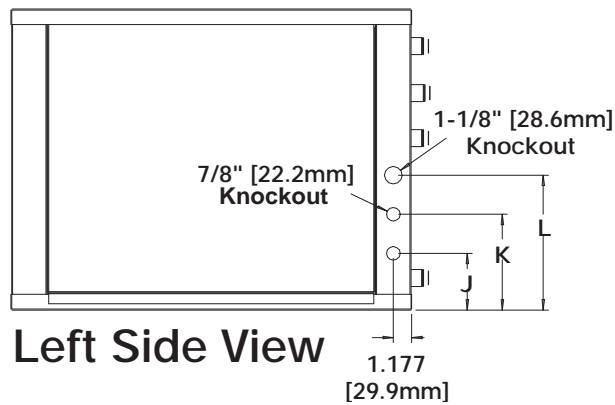
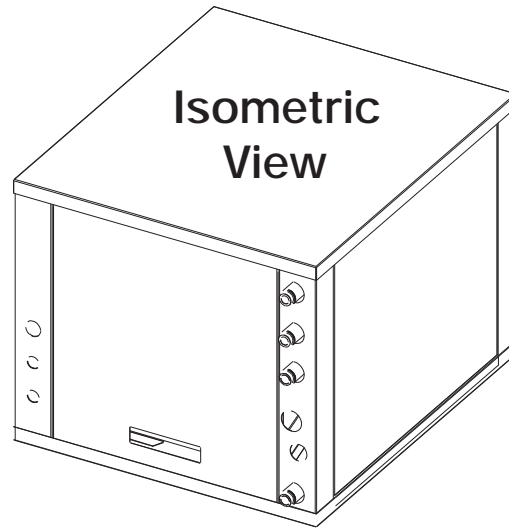
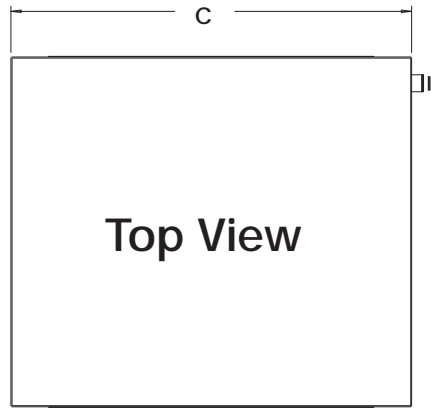

Model	Overall Cabinet			Water Connections							
	A Width	B Height	C Depth	1 Water In/Out	2 HWG In/Out	D1 Water In	D2 Water In	E Water Out	F HWG In	G HWG Out	
026	in [cm]	22.4 [56.9]	19.3 [49.0]	25.6 [65.0]	1"	1"	1.6 [4.1]	2.1 [5.3]	11.0 [27.9]	13.9 [35.3]	16.9 [42.9]
038	in [cm]	25.4 [64.5]	21.3 [54.1]	30.6 [77.7]	1"	1"	1.7 [4.3]	3.4 [8.6]	12.1 [30.7]	15.6 [39.6]	18.9 [48.0]
049	in [cm]	25.4 [64.5]	21.3 [54.1]	30.6 [77.7]	1"	1"	1.7 [4.3]	3.4 [8.6]	12.1 [30.7]	15.6 [39.6]	18.9 [48.0]
064	in [cm]	25.4 [64.5]	21.3 [54.1]	30.6 [77.7]	1"	1"	1.7 [4.3]	3.4 [8.6]	12.1 [30.7]	15.6 [39.6]	18.9 [48.0]

Model	Refrigerant Connection				Electrical Knockouts				
	3 Suction	4 Liquid	H	I	J	K	L	M	
026	in [cm]	3/8"	7/8"	7.3 [18.5]	5.1 [13.0]	3.6 [9.1]	6.1 [15.5]	8.6 [21.8]	1.4 [3.6]
038	in [cm]	3/8"	7/8"	8.4 [21.3]	6.1 [15.5]	3.6 [9.1]	6.1 [15.5]	8.6 [21.8]	1.7 [4.3]
049	in [cm]	1/2"	7/8"	8.4 [21.3]	6.1 [15.5]	3.6 [9.1]	6.1 [15.5]	8.6 [21.8]	1.7 [4.3]
064	in [cm]	1/2"	7/8"	8.4 [21.3]	6.1 [15.5]	3.6 [9.1]	6.1 [15.5]	8.6 [21.8]	1.7 [4.3]

# RPVE OUTDOOR COMPRESSOR SECTION

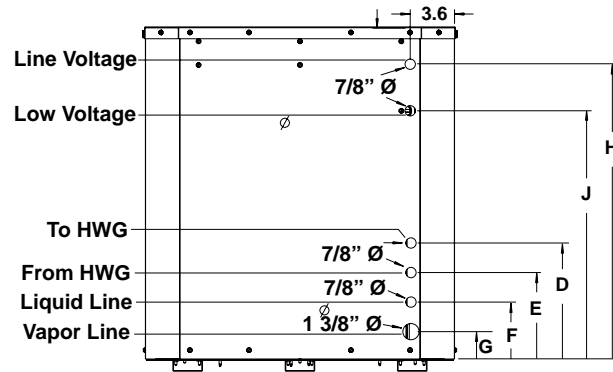

**Back View**

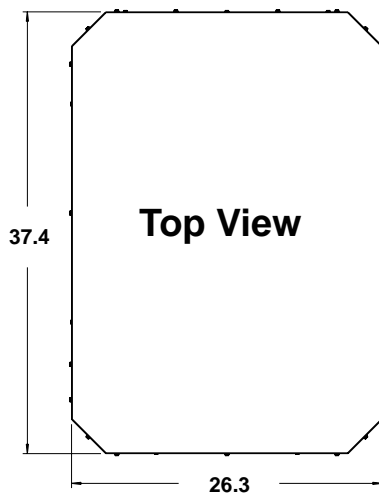

**Top View**

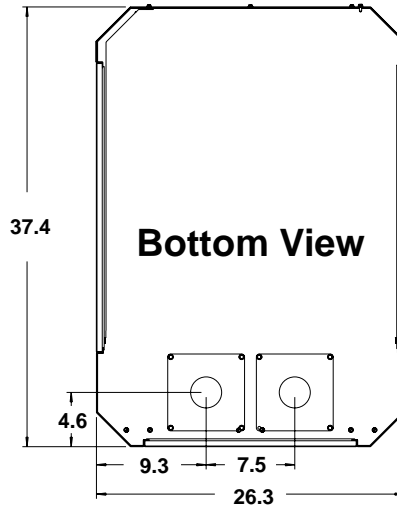

**Bottom View**

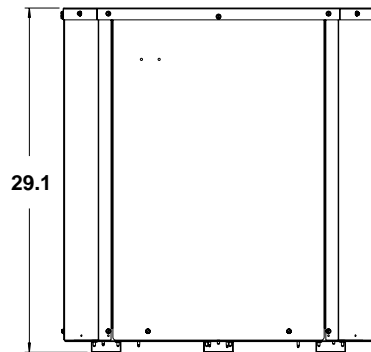

**Front View**

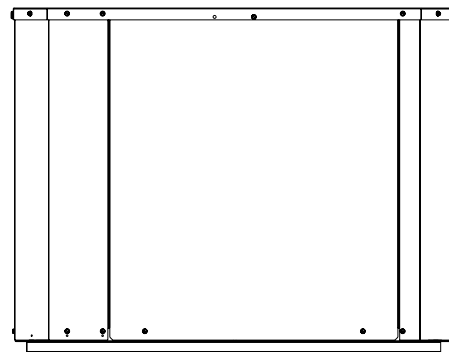

**Side View**

Model	Overall Cabinet			Refrigerant Line Connections							Electrical Knockouts					
	A Width	B Height	C Depth	1 To HWG	2 From HWG	D	E	3 Liquid Line	4 Vapor Line	F	G	Line Voltage	Low Voltage	H	J	
026	in [cm]	26.3 [66.8]	29.1 [73.9]	37.4 [95.0]	5/8"	5/8"	13.0 [33.0]	10.0 [25.4]	3/8"	7/8"	7.0 [17.8]	4.0 [10.2]	7/8"	7/8"	26.1 [66.3]	22.1 [56.1]
038	in [cm]	26.3 [66.8]	29.1 [73.9]	37.4 [95.0]	5/8"	5/8"	13.0 [33.0]	10.0 [25.4]	3/8"	7/8"	7.0 [17.8]	4.0 [10.2]	7/8"	7/8"	26.1 [66.3]	22.1 [56.1]
049	in [cm]	26.3 [66.8]	29.1 [73.9]	37.4 [95.0]	5/8"	5/8"	13.0 [33.0]	10.0 [25.4]	1/2"	7/8"	7.0 [17.8]	4.0 [10.2]	7/8"	7/8"	26.1 [66.3]	22.1 [56.1]
064	in [cm]	26.3 [66.8]	29.1 [73.9]	37.4 [95.0]	5/8"	5/8"	13.0 [33.0]	10.0 [25.4]	1/2"	7/8"	7.0 [17.8]	4.0 [10.2]	7/8"	7/8"	26.1 [66.3]	22.1 [56.1]

---

Before proceeding with installation, refer to installation instructions packaged with each model, as well as complying with all Federal, State, Provincial, and Local codes, regulations, and practices.

**Rheem Heating,  
Cooling and  
Water Heating**

5600 Old Greenwood Road  
Ft. Smith, AR 72908  
(405) 357-0409



---

*"In keeping with its policy of continuous progress and product improvement, Rheem reserves the right to make changes without notice."*